



HL-906

A.R.A.I. APPROVED TOP MARKER LAMP

TOP MARKER LAMP

Tech Details

Size : 316 x 88.5 mm

Housing : ABS

Vacuum Metallized

Lens : White / Red

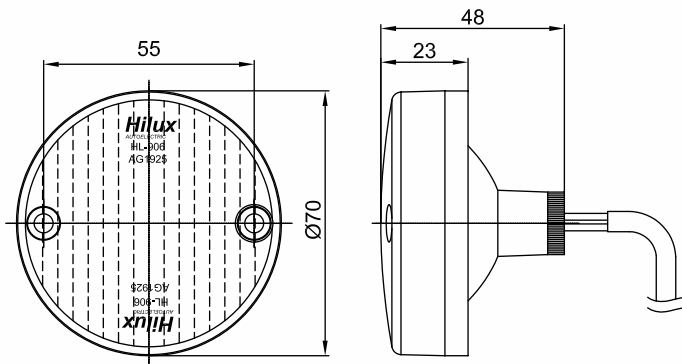

Information shown on this drawing may originate from outside the company no manufacture or resourcing should be made without prior consultation with engineering drawing office

These parts are replacement parts not original parts.

Original part numbers are quoted for reference purposes only.